

1500UR series



www.martekpower.com

Single & Dual Output DC/DC Converter



DESCRIPTIONS

The 1500UR series is a family of miniature 15W DC/DC converters specifically designed for board mount power distribution applications where space is critical, but performance and power cannot be sacrificed. Standard features include an ultra-wide 4:1 input voltage range, efficiency as high as 83% and continuous short circuit protection by input current limiting. 14 models operate from (4:1) input voltage ranges of 10 to 40 VDC or 18 to 72 VDC and provide tightly regulated outputs of 3.3, 5, 12, 15, ± 5 , ± 12 or ± 15 VDC. All models are packaged in a compact, low profile 2" X 2" X 0.4" metal case.

OUTPUT CHARACTERISTICS

	Min	Typ	Max	Unit/Comments
Output Voltage Accuracy				
3.3V Outputs			± 100	mV ¹
All Other Models			± 1.0	% ¹
Voltage Balance:				
Dual Outputs			± 2.0	%; Equal Output Loads
Voltage Adjustment Range				
3.3 Vout			50.0	mV
All Other Models			± 5.0	%; Output Voltage
Line Regulation			± 1.0	% ²
Load Regulation			± 1.0	% ³
Ripple/Noise				
3.3V Outputs		100		mV; p-p, Nom.Line FL, 20Mhz B.W. using 1 μ f bypass capacitor
All Other Models		1		%; p-p, Nom.Line FL, 20Mhz B.W. using 1 μ f bypass capacitor
Short Circuit Protection				Continuous, Automatic Recovery
Transient Recovery Time		300		μ S to within 1% error band for 50% step load change
Temperature Coefficient		± 0.02		% per °C
Over Voltage Protection				See Model Selection Guide

¹ = Output voltage at nominal line & FL

² = Output voltage measured from minimum input line to maximum

³ = Output voltage measured from FL to 10% Load

FEATURES

- 6 sided Continuous Shielding
- 4:1 Ultra-Wide Input Voltage Range
- Output Voltage Trim
- -40°C to +75°C Operating Temperature Range
- Efficiency to 83%
- 1000 VDC Input/Output Isolation
- 10W/In³ Power Density

INPUT CHARACTERISTICS

	Min	Typ	Max	Unit/Comments
Input Voltage				
20 VDC Input Models	10	20	40	VDC
36 VDC Input Models	18	36	72	VDC
Input Fuse Requirements				
20 VDC Input Models		3000		mA; Slow blow type
36 VDC Input Models		2000		mA; Slow blow type
Reflected Ripple Current				See Model Selection Guide
Reverse Polarity Input Current			12	Amp
Input Filter				LC Type

GENERAL CHARACTERISTICS

	Min	Typ	Max	Unit/Comments
Switching Frequency	130			kHz
Isolation Voltage	1000			VDC, 1 minute
Isolation Resistance	1000			Mohm, 500VDC
Isolation Capacitance		100		pF, 100kHz, 1Volt
MTBF (MIL-HBK-217F)	865			Thousand Hours, +25°C, Ground Benign

ENVIRONMENTAL SPECIFICATIONS

	Min	Typ	Max	Unit/Comments
Operating Temp. Range	-40		+75	°C; Ambient
Storage Temp. Range	-55		+125	°C
Relative Humidity			+95	% Humidity; non-condensing
Cooling				Free-Air Convection

PHYSICAL CHARACTERISTICS

	Unit/Comments
Case Size	2.0 X 2.0 X 0.4 inches (51.0 X 51.0 X 10.2 mm)
Case Material	Coated Metal with Non-Conductive Base
Shield Connection	
20 VDC Input Models	Negative Input, Pin 2
36 VDC Input Models	Positive Input, Pin 1
Flammability	UL94V-0
Weight	79 Grams

OUTLINE DRAWING

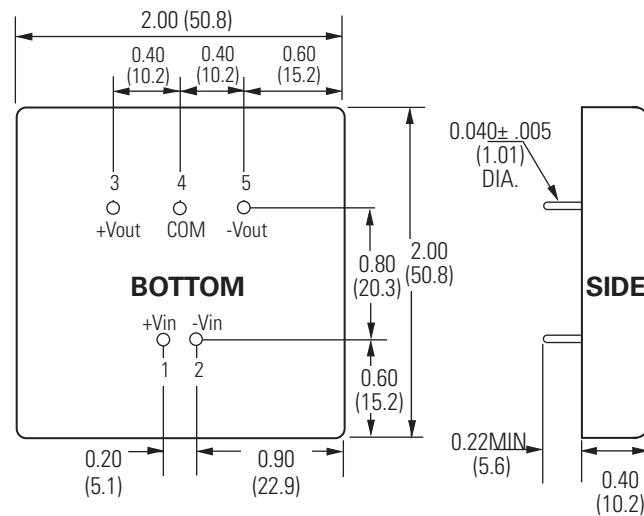

PIN OUT CHART

Pins	Single	Dual
1	+Vin	+ Vin
2	- Vin	- Vin
3	+ Vout	+ Vout
4	Trim	± Common
5	- Vout	- Vout

NC = No Connection

Notes:

1. Unless otherwise specified dimensions are in inches (mm).

Tolerances	Inches	mm
	X.XX = ±0.02	X.X = ±0.5
	X.XXX = ±0.010	X.XX = ±0.25

All specifications are typical at nominal input, nominal load and 25° C unless otherwise specified. External, low ESR, 10 microfarad (minimum) capacitor across output is recommended for operation.

HOW TO ORDER

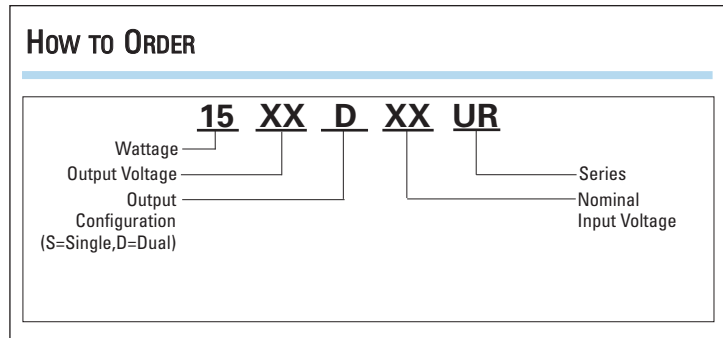

MODEL SELECTION CHART

Model	Nominal Input Voltage (VDC)	Output Voltage (VDC)	Full Load Output Current (mA)	No Load Input Current (mA)	Full Load Input Current (mA)	Reflected Ripple Current (mA)	Output Over Voltage (V)	Efficiency @ FL (%)
1503S20UR	20	3.3	4500	40	900	120	5.8	82
1505S20UR	20	5	3000	40	900	120	6.8	83
1512S20UR	20	12	1250	40	960	120	15	78
1515S20UR	20	15	1000	40	950	120	18	79
1505D20UR	20	±5	±1500	40	920	120	±6.8	81
1512D20UR	20	±12	±625	40	960	120	±15	78
1515D20UR	20	±15	±500	40	1000	120	±18	75
1503S36UR	36	3.3	4500	40	500	60	5.8	82
1505S36UR	36	5	3000	40	500	60	6.8	83
1512S36UR	36	12	1250	40	510	60	15	81
1515S36UR	36	15	1000	40	500	60	18	83
1505D36UR	36	±5	±1500	40	510	60	±6.8	81
1512D36UR	36	±12	±625	40	520	60	±15	80
1515D36UR	36	±15	±500	40	520	60	±18	80

OUTPUT VOLTAGE ADJUSTMENT (1500UR SERIES)

The converter's output voltage may be trimmed to $\pm 10\%$ of the nominal output voltage.

TRIM UP

Trim output voltage up by connecting an external resistor between Pins 4 and 5. Use the following equation. Reference Table 1 for variable A.

$$\text{Radj-up} = \frac{A}{\Delta \%} - 24 \text{ (k}\Omega\text{)}$$

Example:

If we want to trim 5% up for 12V output units, where $A = 1.97$, $\Delta \% = 0.05$

$$\text{Radj-up} = \frac{1.97}{0.05} - 24 \text{ k}\Omega = 15.4 \text{ k}\Omega$$

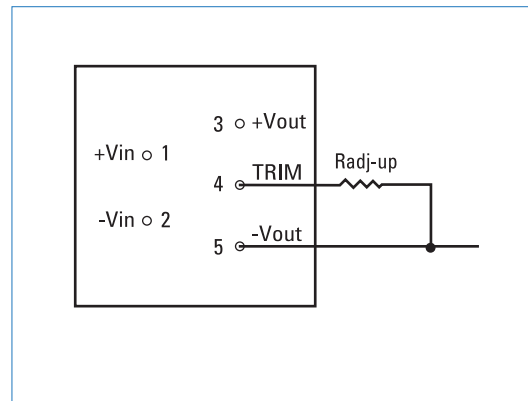

Table 1.

Output Voltage	A
3.3V	0.75
5V	1.25
12V	1.97
15V	2.07

TRIM DOWN

Trim output voltage down by connecting an external resistor between Pins 3 and 4. Use the following equation. Reference Table 2 for variable C and D.

$$\text{Radj-down} = \frac{C}{\Delta \%} - D \text{ (k}\Omega\text{)}$$

Example:

If we want to trim 2% down for 5V output units, where $C = 1.25$, $D = 26.5$, $\Delta \% = 0.02$

$$\text{Radj-down} = \frac{1.25}{0.02} - 26.5 \text{ k}\Omega = 36 \text{ k}\Omega$$

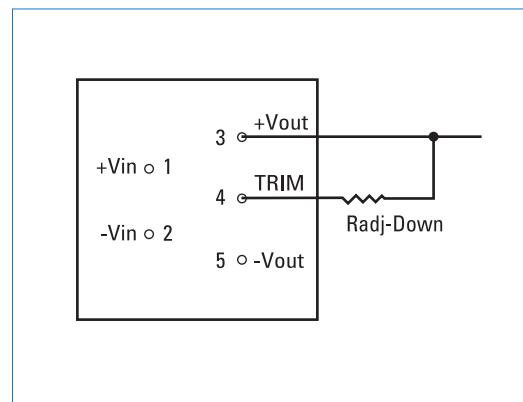

Table 2.

Output Voltage	C	D
3.3V	1.25	26
5V	1.25	26.5
12V	7.55	33.5
15V	10.3	36.4